

## EOD5C70X vgradna pečica



### SteamBake, your at-home bakery

By adding steam, you can create mouth-watering muffins and perfect pies at home with the 600 SteamBake Oven. You can enjoy roasted chicken, lasagna and fish with even cooking results. For crunchy crusts and fluffy insides at the touch of a



### SteamBake for delicious baking

SteamBake lets you create bakery-style results in your own home, at the push of a button. Humidity allows dough to rise up fully, creating deliciously soft insides, while dry heat creates rich, glossy crusts. Enjoy not only delicious bakes, but even roasted chicken and



### Catalytic Cleaning, for an oven that cleans itself

Our Catalytic Cleaning technology means you can say goodbye to build-ups of grease and residue. This self-cleaning technology automatically starts to work when the oven's temperature reaches 250°C. Now cleaning your oven is easy.

### Prednosti izdelka:

- Set exact cooking times with the LED timer display.
- The fan circulates heat consistently and evenly throughout the oven.
- The Multilevel cooking ensures even cooking on all three levels.

### Značilnosti:

- Vgradne pečice
- Večfunkcijska pečica s krožnim grelcem
- Možnost pečenja na 3 nivojih
- Termotimer nadzor pečice
- Vgrezni gumbi
- Halogenska luč pri pečici
- Katalitične obloge, za čisto pečico
- Enostavno čiščenje vrat
- Ventilator za hlajenje
- Priloženi pekači s pečico: 1 pekač za sladice iz sivega emajla, 1 globoki pekač iz sivega emajla
- Število rešetk v pečici: 1 kromirana rešetka
- [http://services.electrolux-medialibrary.com/118ed4c0ee6546f4a7684c7fef8c985aNrZmYkM861d1f/view/WS\\_TN/PSEBPL15PC002027.png](http://services.electrolux-medialibrary.com/118ed4c0ee6546f4a7684c7fef8c985aNrZmYkM861d1f/view/WS_TN/PSEBPL15PC002027.png)
- [http://services.electrolux-medialibrary.com/118ed4c0ee6546f4a7684c7fef8c985aNrZmYkM861d1f/view/WS\\_TN/PSEBPL15PC002009.png](http://services.electrolux-medialibrary.com/118ed4c0ee6546f4a7684c7fef8c985aNrZmYkM861d1f/view/WS_TN/PSEBPL15PC002009.png)
- [http://services.electrolux-medialibrary.com/118ed4c0ee6546f4a7684c7fef8c985aNrZmYkM861d1f/view/WS\\_TN/PSEBPL15PC002010.png](http://services.electrolux-medialibrary.com/118ed4c0ee6546f4a7684c7fef8c985aNrZmYkM861d1f/view/WS_TN/PSEBPL15PC002010.png)
- [http://services.electrolux-medialibrary.com/118ed4c0ee6546f4a7684c7fef8c985aNrZmYkM861d1f/view/WS\\_TN/PSEBPL15PC002012.png](http://services.electrolux-medialibrary.com/118ed4c0ee6546f4a7684c7fef8c985aNrZmYkM861d1f/view/WS_TN/PSEBPL15PC002012.png)
- [http://services.electrolux-medialibrary.com/118ed4c0ee6546f4a7684c7fef8c985aNrZmYkM861d1f/view/WS\\_TN/PSEBPL15PC002025.png](http://services.electrolux-medialibrary.com/118ed4c0ee6546f4a7684c7fef8c985aNrZmYkM861d1f/view/WS_TN/PSEBPL15PC002025.png)
- [http://services.electrolux-medialibrary.com/118ed4c0ee6546f4a7684c7fef8c985aNrZmYkM861d1f/view/WS\\_TN/PSEBPL15PC002027.png](http://services.electrolux-medialibrary.com/118ed4c0ee6546f4a7684c7fef8c985aNrZmYkM861d1f/view/WS_TN/PSEBPL15PC002027.png)

### Tehnične značilnosti:

- Čiščenje pečice : katalitične obloge
- Uporabna prostornina notranjosti (l) : 72
- Razred energijske učinkovitosti : A
- Razpon temperature : 50°C - 275°C
- Glasnost dB(A) : 43
- Zunanje mere (VxŠxG) v mm : 594x596x569
- Vključeni dodatki : enonivojska izvlečna vodila, variabilna
- Notranjost : Sivi emajl
- Vgradne mere (mm) : 600x560x550
- Skupna priključna moč (W) : 2990
- Moč (V) : 220-240
- Varovalka (A) : 16
- Dolžina kabla (m) : 1,6
- Barva : nerjaveče jeklo
- Poraba energije pri običajnem načinu kroženja zraka (kWh/cikel) : 0.95
- PNC koda : 949499310
- Product Partner Code : ER

### Opis aparata:

# EOD5C70X vgradna pečica

PSGBOV180DE00006

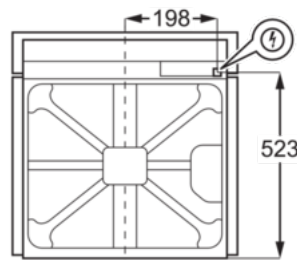
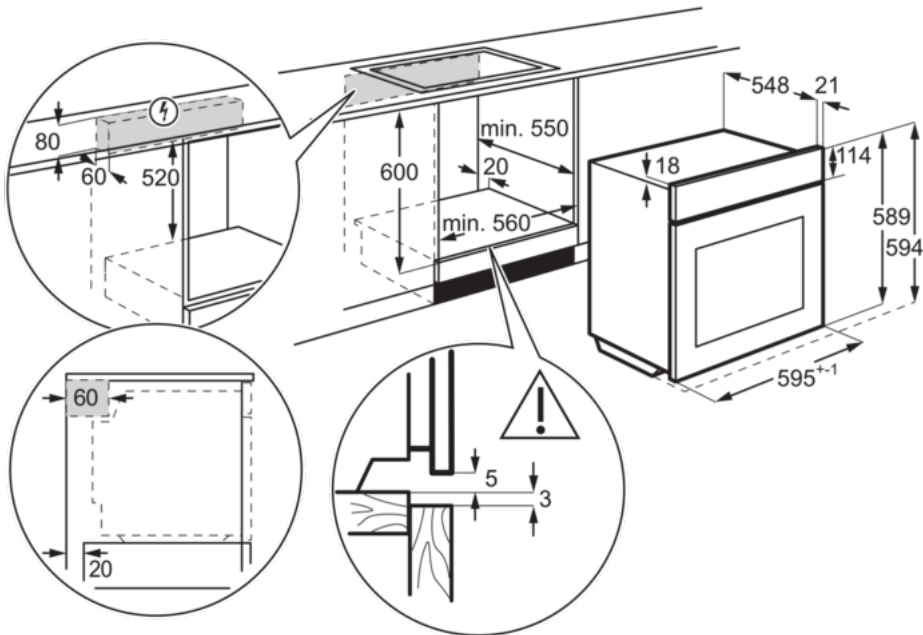

PSGBOV180DE00013

